

HC51 / HC6

RESISTANCE WELD

SPECIFICATION

Frequency Range	1.0 to 20.000 MHz
Frequency Tolerance	± 50 PPM (Standard)
Frequency Stability @ 25EC	± 50 PPM (Standard)
Operating Temperature Range	0EC to 70EC (Standard)
Load Capacitance (C _L)	12pF to 50pF or Series
Shunt Capacitance	7pF Maximum
Drive Level	1mWatt Maximum
Aging	±5 PPM per year Maximum

Dimensions in mm

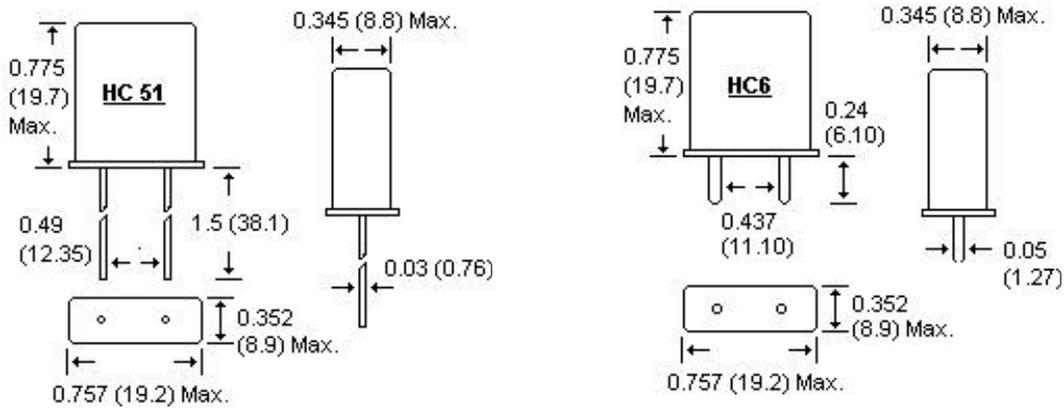

HC51 / HC6 Part Number Break Down

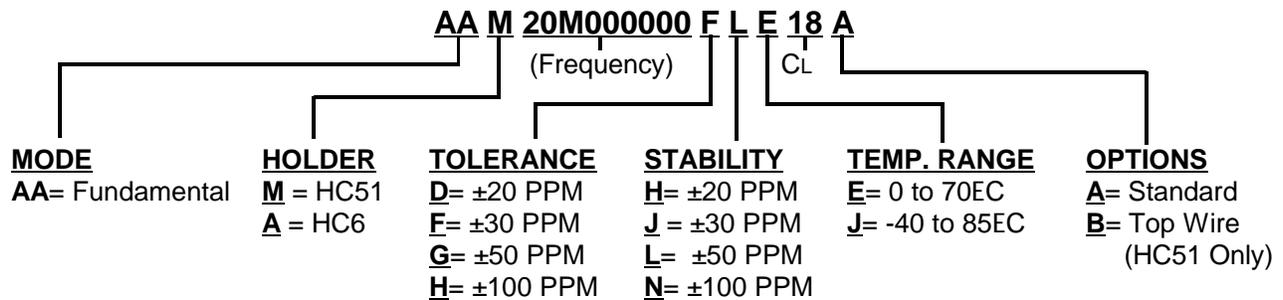

Standard Crystal Corporation 9940 E. Baldwin Place, El Monte, Ca., 91731
 Phone: (800) 423-4578, Fax: (626) 443-9049
www.standardcrystalcorp.com, E-Mail: stdxtl@pacbell.net